



brands you trust.

Installation, Operation & Maintenance Instructions

CRANE Energy, CENTER LINE®
Resilient Seated Butterfly Valves

CRANE®

Energy Flow Solutions

www.craneenergy.com



Contents

Introduction	
Valve Description	3
Valve Design Features	3
Flange and Pipe Schedule Compatibility	3
Gasket Compatibility	3
Operating Pressures	3
Product Identification	3
Installation Recommendations	
Valve Ratings	4
Valve Seat Position	4
Disc Clearances	4
Opening Rotation	4
Installation Position	4
Valve and Flange Preparation	4
Installation Tools	4
Required Bolting	4
Unpacking and Storage Instructions	4
Pre-Installation Procedure	5
Valve Installation Procedure	5-6
Flange Bolting Recommendations (Series 200, 225, 250)	7
Maintenance Instructions	
Safety Precautions	8
General Maintenance	8
Butterfly Valve Assembly and Disassembly (Series 200, 225, 250)	8
Ratchet Handle Mounting Procedure (Series 200, 225, 250)	9
Manual Gear Mounting Procedure (Series 200, 225, 250)	9
Remote Actuator (Male Drive) Mounting Procedure (Series 200, 225, 250)	9
Remote Actuator (Female Drive) Mounting Procedure (Series 200, 225, 250)	9
Butterfly Valve Assembly and Disassembly (Series 700)	10
Mounting of Worm Gear Operators (Series 700)	10
Installing 10 Position Handle (Series 700)	10
Maintenance and Repair (Series 700)	10
Installation Diagram (Series 700)	11
Stud Bolts and Specifications (Series 700)	12
Check Valve Assembly and Disassembly	13
Parts List	14
Center Line Figure Number Systems	
Series 200	15
Series 225	16
Series 250	17
Series 700	18
Series 800	19

Introduction

Valve Description

The Center Line Resilient Seated Butterfly Valve (RSBFV) is designed for use in ASME Class 150 piping systems and is available in both Wafer and Lug style body designs. The standard valve size range available is as follows:

- Series 200 200 psi Standard BFV 2" to 12"
- 150 psi Standard BFV 14" to 48"
- Series 225 285 psi BFV 2" to 24"
- Series 250 285 psi BFV (SS & CS) 2" to 24"
- Series 700 150 psi Standard BFV 1" to 12"
- 100 psi Teflon®-lined Disc 2" to 12"
- Series 800 Check Valve 2" to 20"

Center Line Series 225 Butterfly Valve are also available with an ASME Class 300 bolt pattern for Lug bodies of sizes 2" through 12".

Valve Design Features

- The unique Center Line seat and disc design insures positive valve sealing while maintaining low seating torque.
- All Center Line Butterfly Valve discs are precision machined to a half ball profile, providing a precise disc to seat relationship.
- Center Line's cartridge style seat incorporates an elastomer bonded to a phenolic stabilizing ring, eliminating elastomer movement and reducing seat tearing or fatiguing due to bunching.
- Center Line's basic three bushing design completely isolates the valve shaft from the body, resulting in increased control of the valve disc, lower valve seating torque, and longer valve life.
- The Center Line cartridge seat has a much smaller mass of elastomer than traditional boot seat designs, limiting seat swell and the accompanying variations in seating torque.

Flange and Pipe Schedule Compatibility

The Center Line RSBFV is designed to fit between standard piping flanges as follows:

- ASME 125 Cast Iron Flanges (All Sizes)
- ASME 150 Steel Flanges, Schedule 40 (All Sizes)
- ASME 150 Steel Flanges, Schedule 80 (2" to 10")
- ASME 300 Steel Flanges, Schedule 40
- (Series 225 Lug, 2" to 12" only).

When using Schedule 80 piping, special care must be taken to make sure the valve is centered between the flanges to prevent damage to the disc edge when opening or closing.

Teflon® is a registered trademark of E. I. du Pont de Nemours and Company or its affiliates.

Gasket Compatibility

In the Center Line butterfly valve and check valve design, the elastomer seat extends beyond the valve face and provides a leakproof seal between the valve and the mating pipe flange faces. Gaskets are not needed and should not be used when the valve is installed between standard weldneck or slip-on type flanges.

Operating Pressures

All Center Line Series 200 Butterfly Valves are rated at 200 psi bubble tight shut-off for sizes 2" to 12" and 150 psi bubble tight shut-off for sizes 14" and larger. Center Line Series 225 and 250 Butterfly Valves are rated for bubble tight shut-off at 285 psi. Series 225 and 250 Lug DES 2" to 12" valves are rated to 150 psi max. Series 700 are rated at 150 psi however, for Teflon®-lined disc sizes 1" to 12" are rated 100 psi. Center Line Series 800 Check Valves are rated at a minimum pressure differential of 25 psi and a maximum pressure differential of 150 psi for bubble tight shut-off.

Product Identification

Each Center Line valve has an identification tag attached to the valve body. Information on this tag includes the valve Series Number, materials of construction for the Body, Disc, and Seat, and the valve Pressure Rating.

CENTER LINE

SERIES _____

BODY _____

DISC _____

SEAT _____

RATING _____ **PSI**



Installation Recommendations

Valve Ratings

Center Line valves are intended for use at the pressure indicated on the nameplate attached to each individual valve. Check the valve operating temperature and pressure rating before proceeding with installation.

Valve Seat Position

All Center Line butterfly valves are completely bi-directional, so installation is not dependent on seat orientation. For Center Line Series 800 Check Valves, every effort should be made for installation with backflow protection (no flow) in to the seat side of the valve. Bubble-tight shutoff will be achieved in this orientation with 25 to 150 psi ΔP across the valve.

Disc Clearances

Prior to installing the valve, it is important to make sure the ID of the pipe and the pipe flanges are large enough to allow the disc edge to swing into the opening without interference. Damage to the disc edge can severely affect the performance of the valve. Flange and pipe schedule compatibility for Center Line valves is shown in Section 1 of this manual.

Opening Rotation

The Center Line valve disc can rotate 360° without damaging the valve or elastomer seat. The valve is designed to open with either clockwise or counterclockwise rotation of the shaft.

Installation Position

To prevent damage to the disc and seat during installation, the valve disc should be slightly open but not extending beyond the valve liner face. Positioning the disc in this “almost closed” position will reduce seat interference and initial torque build-up during valve installation.

In general, it is preferable to install RSBFV's with the shaft in a horizontal orientation. In this position, shaft and disc weights are evenly distributed, minimizing seat wear.

Center Line butterfly valves are designed to operate between two flanges. If the valve installation calls for the use of one pipe flange only, a Lug style valve with Dead End Service feature must be used.

Valve and Flange Preparation

If the valve and mating pipe are properly prepared for installation, future problems can be avoided. All valve seat and pipe flange faces should be free of dirt, grit, dents, or surface irregularities which may disrupt flange sealing and cause external leakage. The valve disc sealing surface should also be inspected to eliminate any dirt or foreign material that will adversely affect the operation of the valve.

Installation Tools

The only tool required in the installation of a Center Line RSBFV is a wrench suitable for tightening the flange bolts and/or nuts required to secure the valve in-line. A hoist may be required to help manipulate valves 10" and larger. Smaller sized valves can usually be installed by hand. Temporary pipe supports may be used to keep mating flange faces parallel in order to aid in valve installation.

Required Bolting

The table outlined on Page 7 is furnished to provide information regarding the size, type, and quantity of bolting recommended for the installation of Center Line RSBFV's. This table is intended for use as a planning and procurement guide. All recommendations are based on pipe flanges in accordance with ASME 125/150 specifications. Flange bolting is not included with the valve shipment.

Unpacking and Storage Instructions

1. Check the packing list against the valve received to verify that the size, material, and trim are correct.
2. Check to make sure that the valve and operator were not damaged during shipment.
3. When lifting the valve, take care to avoid damage to the flange faces, disc sealing edge, or operator.
4. If the valve is to be stored before being installed, it should be protected from harsh environmental conditions.
5. Store the valve with the disc in the “almost closed” position to protect the sealing edge and the seat.
6. Keep the valve in a clean location, away from dirt, debris and corrosive materials.
7. Keep the valve in a dry area with the flanges protected and on a suitable skid or pallet.
8. Keep the valve in a cool location if possible, out of direct sunlight.

Installation Recommendations

Pre-Installation Procedure

1. Remove any protective flange covers from the valve.
2. Inspect the valve to be certain the waterway is free from dirt and foreign matter. Be certain the adjoining pipeline is free from any foreign material such as rust and pipe scale or welding slag that could damage the seat and disc sealing surfaces.
3. Any actuator should be mounted on the valve prior to installation to facilitate proper alignment of the disc in the valve seat.
4. Check the valve identification tag for materials, and operating pressure to be sure they are correct for the application.

WARNING! *Personal Injury or property damage may result if the valve is installed where service conditions could exceed the valve ratings.*

5. Check the flange bolts or studs for proper size, threading, and length.

Valve Installation Procedure

Position the connecting pipe flanges in the line to insure proper alignment prior to valve installation. Spread the pipe flanges apart enough to allow the valve body to be located between the flanges without actually contacting the flange surfaces (See Figure 1.) Exercise particular care in handling the valve so as to prevent possible damage to the disc or seat faces.

For Wafer style valves:

- a. Place the valve between the flanges.
- b. Loosely install the two upper and lower flange bolts that pass through the body alignment holes.
- c. Install the remaining flange bolts, shifting the valve as necessary to permit the bolts to pass by the valve body. Hand tighten all bolts as necessary.

For Lug style valves:

- a. Place the valve between the flanges.
- b. Install all bolts between the valve and the mating flanges. Hand tighten bolts as necessary.

For Check Valves:

- a. Note the opening direction of the disc for proper valve orientation.
 - b. Place the valve between the flanges using the four (4) alignment holes provided.
 - c. Install the remaining flange bolts, shifting the valve as necessary to permit the bolts to pass by the valve body. Hand tighten bolts as necessary.
1. Before completing the tightening of any bolts, the valve should be centered between the flanges and then carefully opened and closed to insure free, unobstructed disc movement (See Figure 2.)
 2. Using the sequence shown in Figure 3, tighten the flange bolts evenly to assure uniform compression.
 3. If an actuator is to be used, air hoses or electricity should be connected to the unit as specified by the actuator manufacturer.
 4. Cycle the valve to the fully open position, then back to the fully closed position, checking the actuator travel stop settings for proper disc alignment. The valve should be operated to assure that no binding is taking place.
 5. The valve is now ready for operation.

Remember: *Install the valve with the disc in the "ALMOST CLOSED" position. Do not use any flange gaskets.*

Figure 1 Initial Installation of Valve

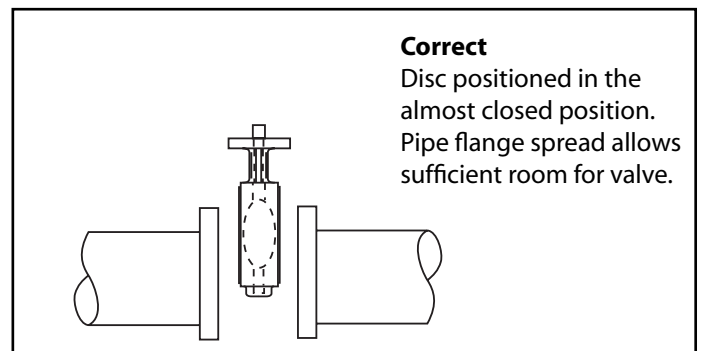
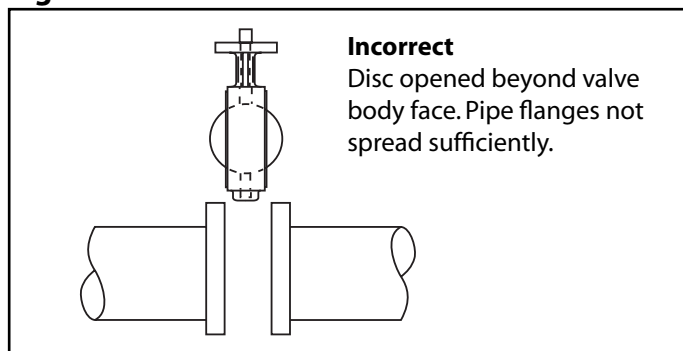

Installation Recommendations

Figure 2 Centering and Flanging of Valve

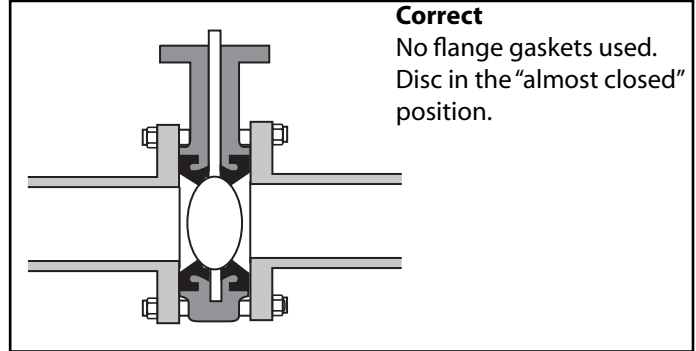
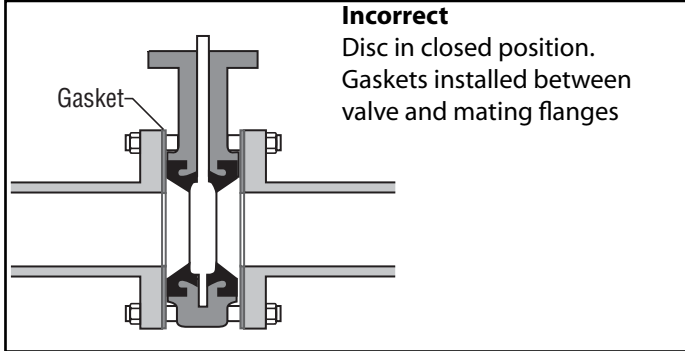

Figure 3 Flange Bolt Tightening Sequence

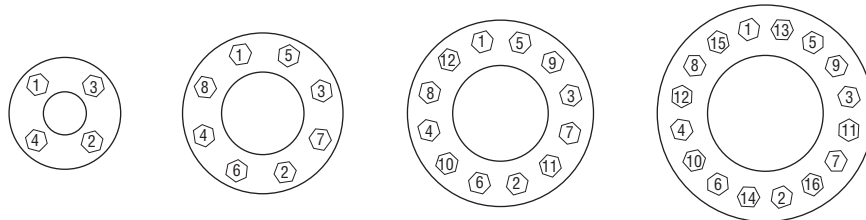
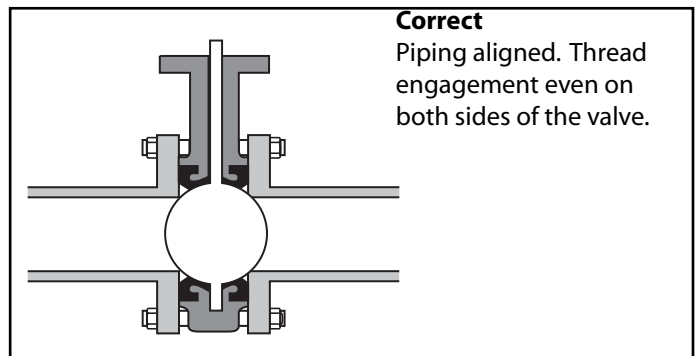
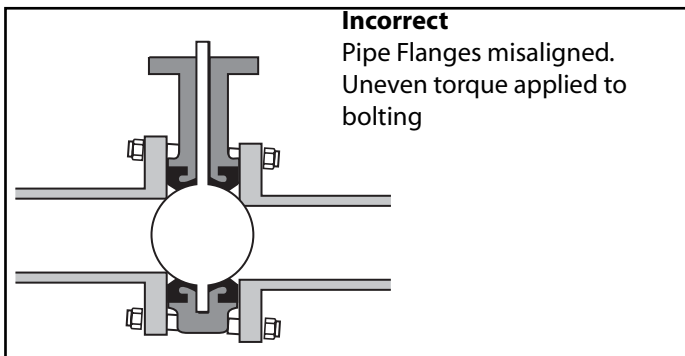

Figure 4 Final Valve Alignment and Tightening of Flange Bolts



Installation Recommendations

Flange Bolting Recommendations

Center Line Wafer, Lug and Double Flange and Check Valves, 2"-48", ASME 125/150 Bolt Pattern

Size	Thread Size	Number Required	Stud Length Wafer B'fly (in.)	Stud Length Double Flange (in.)	Stud Length Check Valve (in.)	Bolt Length Lug B'fly (in.)	Req. Torque (Ft-lbs)
2"	5/8-11	4	4.750	-	5.125	1.250	15-60
2 1/2"	5/8-11	4	5.250	-	5.375	1.500	15-60
3"	5/8-11	4	5.250	-	5.375	1.500	15-60
4"	5/8-11	8	5.750	-	6.000	1.750	15-60
5"	3/4-10	8	6.000	-	6.375	1.750	25-100
6"	3/4-10	8	6.250	-	7.000	2.000	25-100
8"	3/4-10	8	6.750	-	8.000	2.250	25-100
10"	7/8-9	12	7.250	-	8.500	2.250	50-200
12"	7/8-9	12	7.750	-	9.750	2.500	50-200
14"	1-8	12	8.250	-	12.250	2.750	70-300
16"	1-8	16	8.750	-	11.750	2.750	70-300
18"	1 1/8-7	16	10.000	-	13.000	3.500	100-400
20" Series 200	1 1/8-7	20	11.250	-	14.500	4.250	100-400
20" Series 225	1 1/8-7	16 + 4 ea.	11.250 5.000	-	-	4.250 3.250	100-400 100-400
24" Series 200	1 1/4-7	20	12.750	-	15.125	4.750	150-500
24" Series 225	1 1/4-7	16 +4 ea.	12.750 5.250	-	-	4.750 3.750	150-500 150-500
28" Double Flange	1 1/4-7	24 +4 ea.	-	3.5 16.0	-	-	387
30" Series 200	1 1/4-7	24 +4 ea.	13.750 5.750	-	-	4.500 4.250	150-500 150-500
30" Double Flange	1 1/4-7	24 +4 ea.	-	3.5 16.0	-	-	387
32" Double Flange	1 1/2-6	24 +4 ea.	-	4.0 18.0	-	-	644
36" Double Flange	1 1/2-6	28 +4 ea.	-	4.0 19.0	-	-	644
42" Double Flange	1 1/2-6	32 +4 ea.	-	4.5 20.75	-	-	644
48" Double Flange	1 1/2-6	40 +4 ea.	-	5.0 22.75	-	-	644

Bolting and torque recommendations are made without a warranty, and apply only to steel weld-neck or slip-on flanges. The use of lock washers and/or lubrication with the bolting will affect stated torque values.

For Series 700 Stud and Bolting Recommendations see page 12.

Maintenance Instructions - Series 200, 225, 250

Safety Precautions Butterfly Valve Assembly

Before removing the valve from the line or loosening any bolts, it is important to verify the following conditions:

1. Be sure the line is depressurized and drained.
2. Be sure of the pipeline media. Proper care should be taken for protection against toxic and/or flammable fluids.
3. Never remove the valve without an Operator (Manual or Automatic) already attached to the valve shaft.
4. Never remove the Operator from the valve while the valve is in the pipeline under pressure.
5. Always be sure that the disc is in the closed position before removing the valve.

General Maintenance

The following periodic preventative maintenance practices are recommended for all Center Line Butterfly Valves.

1. Operate the valve from full open to full closed to assure operability.
2. Check flange bolting for evidence of loosening and correct as needed.
3. Inspect the valve and surrounding area for previous or existing leakage at flange faces or shaft connections.
4. Check piping and/or wiring to actuators and related equipment for looseness and correct as needed.

Butterfly Valve Disassembly*

1. Position valve flat with the disc in the closed position.
2. Loosen the taper pin(s) from the valve disc using a hammer and punch. **NOTE: Punch should be of same size or larger diameter as small end of taper pin to avoid mushrooming of taper pin.**
3. Remove taper pin(s) from disc. Extract the valve shaft from the body using a twisting motion.
4. Remove the valve disc from body making sure not to damage the seat or disc sealing edge.
5. Cartridge seat removal can be accomplished from either direction by applying pressure evenly on one face to push the seat through the body. If the valve is of dead end service design, remove set screws around periphery of body extending into seat prior to seat removal.
6. Remove shaft bushings from body as required.

Butterfly Valve Assembly*

1. Thoroughly clean all parts. Inspect components for any defects.
2. Apply a small amount of silicone grease to the inside surfaces of the body, including the upper and lower shaft holes.
3. Insert the shaft bushings into the body being careful not

to allow intrusion into the body seat bore.

4. Install the seat into the center of the body, making sure the shaft holes in the seat line up with the holes in the body.

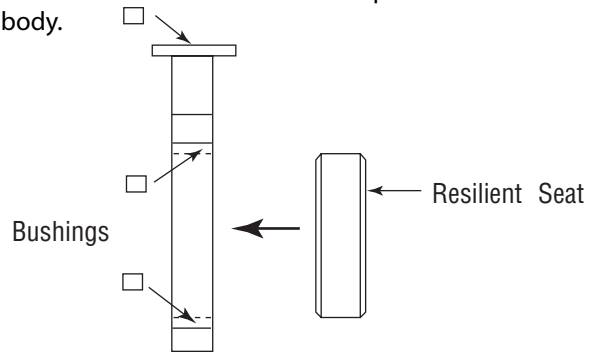

5. Completely coat the inside surfaces of the seat with silicone grease. Carefully push the disc into the seat in the open position (90 degrees to the body.) Line up the shaft holes of the disc as close as possible with the shaft holes in the seat body.

6. Insert the shaft through the body and disc, use a twisting motion to align the keyway parallel with the disc.

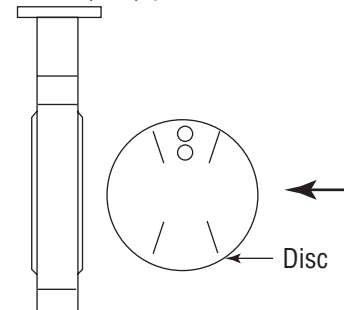

7. Insert taper pin(s) into the disc and set with two or three sharp blows. Wipe dust shield o-ring with silicone grease and place over the shaft into the top of the body.

8. If the valve is of dead end service design, insert set screws through the body into the seat.

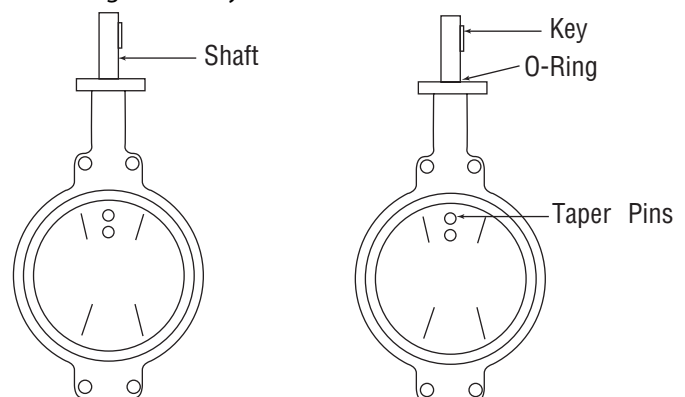

Maintenance Instructions - Series 200, 225, 250

Ratchet Handle Mounting Procedure

1. Position the disc in the closed position.
2. Install the ratchet plate using machine bolts, nuts and lock washers, but do not tighten the fasteners.
3. Install the drive key in the shaft. Tap the key into place to ensure it is fully seated in the keyway .
4. Install the handle so that it is parallel with the disc face. The locking lever must be fully retracted before it will pass through the ratchet plate. Tighten the set screw in the handle against the key.
5. With the handle installed flush with the ratchet plate, engage the locking lever with the ratchet plate. Using the handle, adjust the position of the ratchet plate until the disc face is parallel with the valve face, then tighten the fasteners securely.

Manual Gear Mounting Procedure

1. Position the disc in the closed position.
2. Install the drive key in the shaft. Tap the key into place to ensure it is fully seated.
3. Rotate the gear shaft to the full clockwise position. Align the keyway in the gearbox bore with the key in the shaft and slide the gearbox onto the shaft.
4. Fasten the gearbox to the mounting bracket with the appropriate machine bolts and lock washers. It may be necessary to rotate the gear shaft slightly to align the mounting holes in the gear with the plate.
5. Adjust the stops in the gearbox to position the face of the disc parallel with the face of the valve in the closed position and perpendicular to the face of the valve in the open position.

Remote Actuator (Male Drive) Mounting Procedure

1. Position the disc in the closed position.
2. Install the actuator mounting bracket on the valve body with the actuator mounting holes facing up-ward. Fasten the bracket securely in place with the appropriate machine bolts, nuts, and lock washers.
3. Install the drive key in the keyway of the shaft. Tap the key in place to insure it is fully seated.
4. Install the drive coupling on the shaft by lining up the proper keyway in the coupling with the key in the shaft.
5. Rotate the actuator shaft to the full clockwise position. Align the drive coupling with the actuator shaft and install the actuator on the mounting bracket.
6. Fasten the actuator to the mounting bracket with the appropriate machine bolts and lock washers. It may be necessary to slightly rotate the actuator shaft to align the mounting holes in the actuator with the mounting bracket.

7. Adjust the stops in the actuator to position the face of the disc parallel with the face of the valve body in the closed position and perpendicular to the face of the valve body in the open position.

Remote Actuator (Female Drive) Mounting Procedure

1. Position the disc in the closed position.
2. Install the actuator mounting bracket on the valve body with the actuator mounting holes facing up. Fasten the bracket securely in place with the appropriate machine bolts, nuts, and lock washers.
3. Install the drive key in the shaft. Tap the key in place to insure it is fully seated.
4. Install the drive coupling on the shaft by lining up the proper coupling keyway with the key in the shaft.
5. Install the drive key in the drive coupling. Tap the key in place to insure it is properly seated.
6. Rotate the actuator to the full clockwise position. Align the keyway in the actuator bore with the key in the drive coupling and slide the actuator on the drive coupling.
7. Fasten the actuator to the mounting bracket with the appropriate machine bolts and lock washers. It may be necessary to rotate the actuator slightly to align the actuator with the mounting bracket.
8. Adjust the stops in the actuator to position the face of the disc parallel with the face of the valve body in the closed position and perpendicular to the face of the valve body in the open position.



Maintenance Instructions - Series 700

Assembly and Disassembly of Series 700 Valves

1. Remove nuts and bolts from each side of the housing. The assembler should insert top stem packing and stem bushing in neck of housing size 2", 2 1/2" and 3". Top Teflon® O-seals should be placed in O-seal machined groove, top and bottom of housing in stem hole area. Size 4" through 12" require a bottom bushing which should be inserted at this time.
2. The Teflon® EPDM backed seat should be heated in water so that the seat becomes resilient and seat is softened. The inserting of the disc/stem becomes easier and prevents damage to Teflon® portion of seat. At this time the assembler should insert the long portion of the disc/stem into the stem hole in the seat. The flats of the disc/stem should now be placed in a table vice. Grasp the seat and pull the seat up to the hub area of the seat, push in on seat while pulling upward and insert opposite stem hole over short portion of disc/stem. Push top and bottom of seat as close to hubs as possible.
3. At this time the neck port of the housing should be placed in a table vice with the neck port of the housing facing downward. **NOTE: a couple of shop towels or rags should be placed in table vice to protect housing finish.** At that time assembler should take disc/stem-seat combination and insert long end of assembly down through the stem hole in the neck. When the seat reaches the housing a blunt screw driver may be needed to help clear the seat over the dove tail portion of the housing. Once in place, the small portion of the housing should be placed over the short end of disc/stem seat in the same method.
4. Pushing on top part of housing, insert housing bolts **NOTE: a pair of vice grips or channel locks may be required to pull opposite side of housing into place.** Once bolts are started, tighten opposite sides of housing until housing is tight.
5. Reverse procedures for disassembly.

Mounting of Worm Gear Operators

Gear operators (worm gear operators) are installed the same, 2" through 12". Operators are mounted to top plate of valve. There are two bolts, which hold the operator in place with two adjustment bolts. These bolts adjust disc/stem in the seat for proper sealing. They work opposite of direction in which they are mounted. Example: The right hand bolt adjusts the left side of disc/stem. When adjusted properly you should have a perfect stop inside seat and disc/stem be perfectly open 90 degrees at other stop.

Locking device is assembled by sliding larger part of device over shaft of gear operator. Once near the housing portion of gear operator the assembler will see a bolt that must be removed from housing, after removing bolt, slide locking device over housing and replace bolt. The smaller piece of assembly is slide over shaft and slide up next to larger portion of assembly. Once gear is adjusted to proper position tighten allen screw of small collar at locking position.

Installing 10 Position Handle

All 10 position handles are installed the same. Handle plates (notch plates) are installed first. Install at the position desired. Line holes up between plate and top plate of housing. Tighten bolts to a semi-tight position. Place handle on stem, insert into notch plate. Find desired position then tighten bolts. If positioning is satisfactory, tighten handle to stem. Operate, if not satisfactory repeat process till satisfactory.

Maintenance and Repair for Center Line Series 700 Butterfly Valves

Due to the design of the Center Line series 700 Butterfly Valve, no routine maintenance or lubrication is required. Should any components require replacement please follow the recommended Disassembly and Assembly instruction for each series of valve.

Maintenance Instructions - Series 700

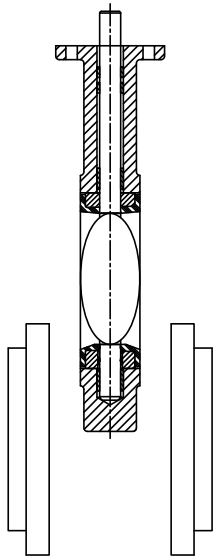

Correct

Open pipework flanges to allow entry of valve without rubbing against the seat. Rotate valve handle or actuator to position disc about 1/4" from the outside edge of the seat (as shown). This will project disc edge from bumping pipework, and reduce seat interference and initial torque build-up.

Incorrect

DO NOT try to install valve with pipework flanges spread insufficiently. This will damage the valve seat and prevent the valve from operating properly. DO NOT install valve with disc in open position (as shown), or disc will impact pipework flanges and damage polished sealing edge of disc.

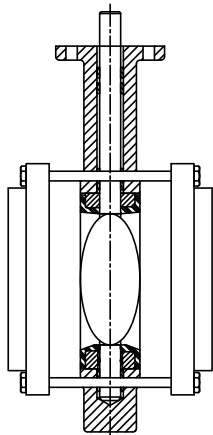
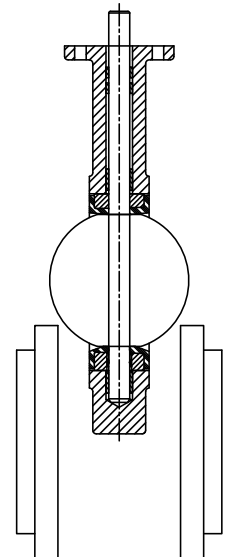

Correct

Position the valve between pipework flanges and assemble the valve housing to the flanges, using all required flange bolts. DO NOT USE ANY TYPE OF FLANGE GASKETS. The O-ring sealing section of the butterfly valve seat provides a positive seal to all popular flanges.

Incorrect

DO NOT try to install the valve with the disc fully closed. Remove actuator if necessary, to allow slight opening of disc. Installation with disc fully closed will cause seat distortion because of seat rubber trying to close around disc edge (as shown). This installation will cause excessive torque in initial operation.

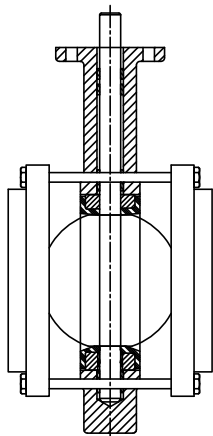
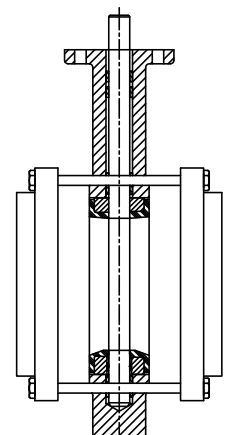

Correct

Turn the valve disc to the full open position. Center the valve housing in the flanges, and hand-tighten bolts. Slowly close the valve to check for clearance between valve disc and pipe or Flange I.D. If valve disc hits, reposition valve as necessary. Re-open valve disc to full open position and cross tighten all bolts to proper torque specification.

Incorrect

DO NOT misalign valve housing or pipework (as shown). Misalignment may cause interference between disc edge and flange face. This will result in leakage, excessive torque and possible damage to disc and seat. Operation of valve in misaligned flanges may also create a pocket where flowing media may come entrapped.

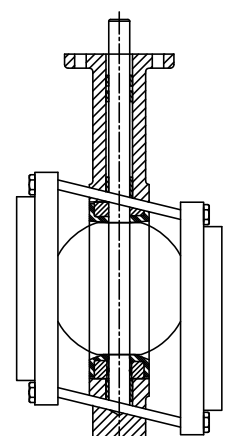

Maintenance Instructions - Series 700

Stud and Bolt Specification (Series 700)

Flange Bolts and Screws Required for Series 700 Valves between 150# ASME Flanges

Valve Size	Heavy Hex Bolts & Nuts			Regular Hex Head Cap Screws with N-C Threads		
	Diameter D (in.)	Length L1 (in.)	Number Required	Diameter D (in.)	Length L2 (in.)	Number Required
2"	5/8	4	4	5/8	1 1/2	8
3"	5/8	4 1/2	4	5/8	1 3/4	8
4"	5/8	5	8	5/8	1 3/4	16
5"	3/4	5	8	3/4	1 3/4	16
6"	3/4	5	8	3/4	2	16
8"	3/4	6	8	3/4	2 1/4	16
10"	7/8	6	12	7/8	2 1/4	24
12"	7/8	6 1/2	12	7/8	2 1/2	24

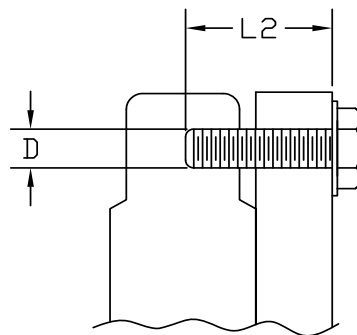
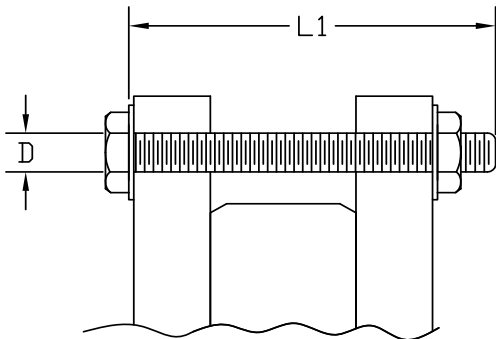

Maintenance Instructions - Check Valves

Check Valve Disassembly

1. Remove set screw (7) from the alignment body (1).
2. Remove the valve insert (4) from the alignment body (1).
3. Remove shaft plugs (8) from the insert with a screwdriver.
NOTE: plugs are sometimes difficult to loosen. When this happens, apply heat with small torch directly to the plug for 30 seconds. Do not allow the flame to touch the elastomer face on either side of the inset.
4. Remove the shaft (3) from the valve insert. **NOTE: when the stem is removed, the springs (5) behind the check plates (2) will be released. On sizes 8" to 20", these springs must be securely held to prevent recoil upon loss of tension.**
5. Remove the check valve plates (2) from the valve insert. Note the location of the thrust washers (6). These must be replaced in the same location upon reassembly.

Check Valve Assembly

1. Place valve plates (2) into the insert (4).
2. Replace thrust washers (6) in original location.
3. Install shaft (3) half way into the insert.
4. Pre-load first spring (5) with 1/2 turn windup. Do not unwind spring. Legs of spring should be horizontal, 180° apart.
5. Place spring (5) on shaft (3) and release. Install shaft (3) just far enough to allow installation of second spring (5).
6. Push shaft (3) completely into insert (4).
7. Replace shaft plugs (8) in insert (4) with pipe thread sealant and tighten firmly.
8. Place insert (4) in body (1) with tapped hole in body aligned with drill point in insert.
9. Replace set screw (7) and tighten.

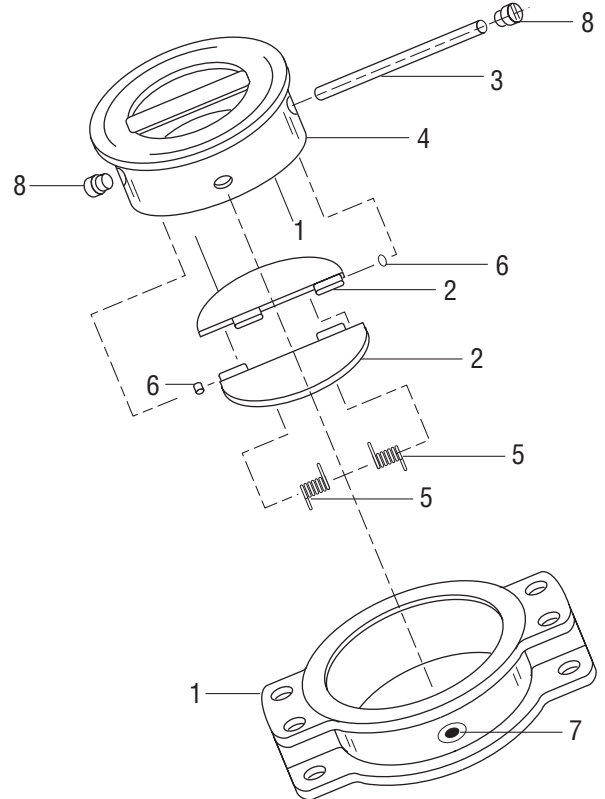

Parts List

Series 200, 225, 250 Butterfly Valve

Item	Description
1	Body
2	Disc
3	Seat
4	Shaft
5	Taper Pin
6	Key
7	O-ring
8	Bushing
9	Bushing
10	Bushing

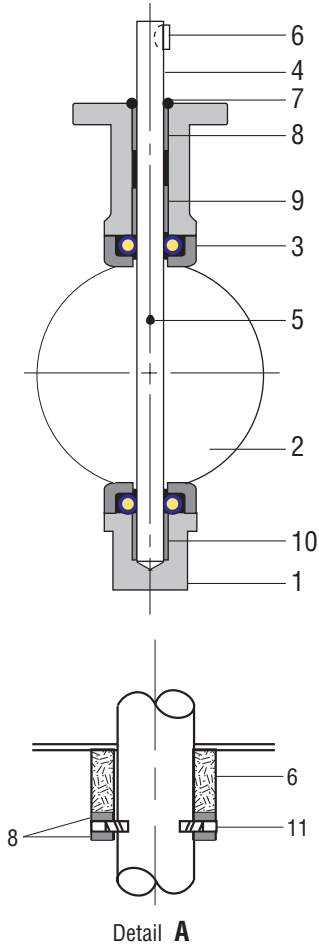

Series 700 Butterfly Valve

Item	Description
1	Mounting Flange
2	Stem Bushings
3	Weather Seal
4	Disc/Stem
5	Seat
6	Seat Face
7	Body

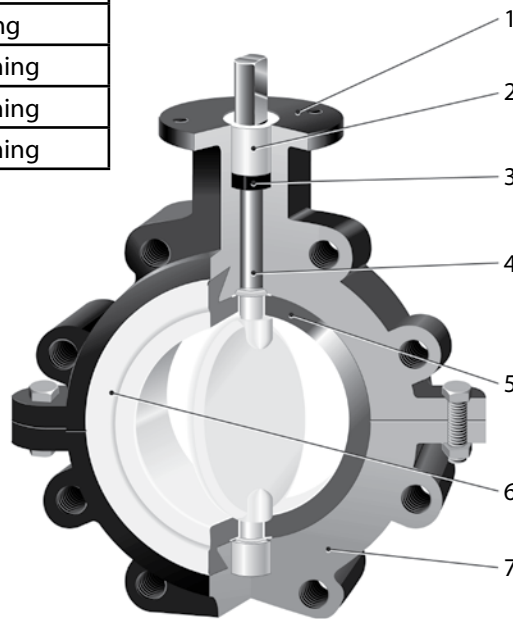

Series 800 Check Valve

Item	Description
1	Shaft
2	Shaft Plug (Qty 2)
3	Plate (Qty 2)
4	Thrust Washer (Qty 4)
5	Spring (Qty 2)
6	Alignment Body
7	Set Screw
8	Plate Travel Stop (14" and larger)

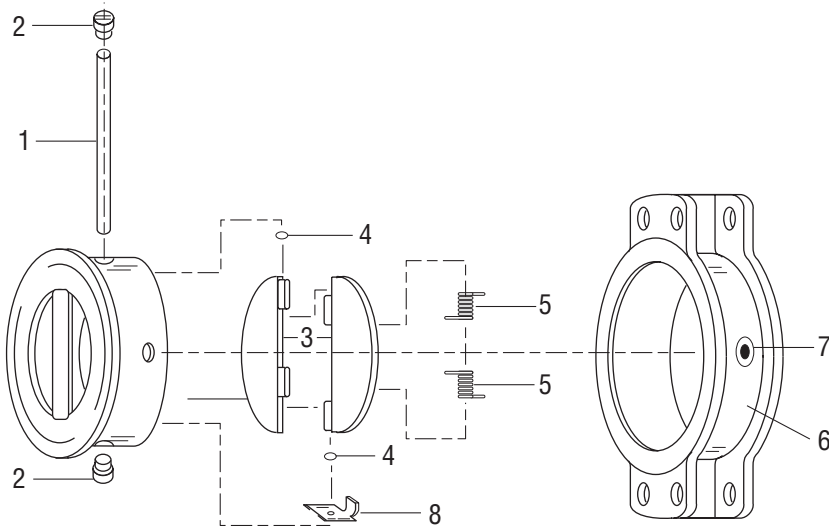

Figure Number System - Series 200

Series 200 1 1 2 3 4 5 6 7 8 9 - 10

1. Size	Code	5. Disc	Code	9. Actuator	Code
2"	02	Ductile Iron-ENP (2"-12")	2	Handle (10 positions)	2
2½"	25	316 SS	4	Infinite/Lockable (2"-6") (10 positions)	3
3"	03	Ductile Iron (14"-48")	5	Infinite (8")	4
to		Aluminum Bronze (2"-48")	6	Gear Operator	5
48"	48	Monel® 400	7	Double Acting	6
				Fail Close (SR)	7
				Fail Open (SR)	8
				Electric	9
				Gear Operating/Balancing	G
				Buried Gear/2" Nut	C
				Chain Wheel	U
				None	X
2. Series/Style	Code	6. Shaft	Code	10. Special Features	Code
Wafer (2"-30")	A	416 SS	1	Custom Product	D
Lug (2"-30")	B	316 SS*	4	CE Marked - Non-Impact Tested	P
Lug/Deadend (2"-30")	C	Monel® 400	7		
Flange (28"-48")	D	17-4 PH	9		
		*Standard with 316SS Disc only.			
3. Body	Code	7. Bushing	Code		
Epoxy Coated CI (A126) (2"-12")	S	Bronze	0		
Epoxy Coated DI (A536) (2"-12")	V	PTFE	3		
Cast Iron (A126) (2"-30")	1				
Ductile Iron (A536) (14"-48")	2				
Ductile Iron (A395) (2"-48")	G				
4. Pressure	Code	8. Seat/Liner	Code		
200 PSI (2"-12")	0	Buna-N	1		
75 PSI Undercut	3	Abrasion Resistant Buna-N	2		
150 PSI (14"-48")	6	Black Neoprene	3		
125 PSI (PTFE seat) (2"-12")	8	EPDM	5		
		Viton® (275°F)	6		
		Perox. Cured Buna-N	8		
		PTFE/Buna-N**	L		
		Viton® (400°F)	P		
		EPDM (FDA)	V		
		White Buna-N (FDA)	W		
		Potable water EPDM	D		
		White Buna-N	B		

** 2½" & 5" PTFE/Buna-N not available.

Viton® is a registered trademark of DuPont Performance Elastomers L.L.C.
 Monel® is a registered trademark of Special Metals Corporation.

Figure Number System - Series 225

Series 225



1. Size	Code	4. Pressure	Code	8. Seat/Liner	Code
2"	02	200 PSI (2"-12") DES*	0	Buna-N	1
2½"	25	285 PSI	5	Neoprene	3
3"	03	150 PSI (14"-24") DES*	6	EPDM	5
to				Viton® (275°F)	6
24"	24			Viton® (400°F)	P
				EPDM (FDA)	V
				White Buna-N	B

2. Series/Style	Code	5. Disc	Code	9. Actuator	Code
Wafer	J	DI - ENP (2"-12")	2	Handle	2
Lug	K	316 SS	4	Infinite/Lockable (2"-6")	3
Lug Dead End	L	DI - (14"-24")	5	Infinite (8")	4
Lug ASME 300 BC	M	Aluminum Bronze	6	Gear Operator	5
Lug ASME 300 DES	N	Monel®	7	Double Acting	6
				Fail Close - SR	7
				Fail Open - SR	8
				Electric	9
				Gear Operator/Balancing	G
				Buried Gear/2" Nut	D
				Chain Wheel	U
				None	X

3. Body	Code	6. Shaft	Code	10. Special Features	Code
Ductile Iron (A536)	2	416 SS	1	Custom Product	D
Epoxy Coated DI (A536)	V	316 SS	4	CE Marked - Non-Impact Tested	P
Ductile Iron (A395)	G	Monel® (B865-K500 CL-A)	7		
		17-4 PH	9		

7. Bushings	Code
PTFE	3

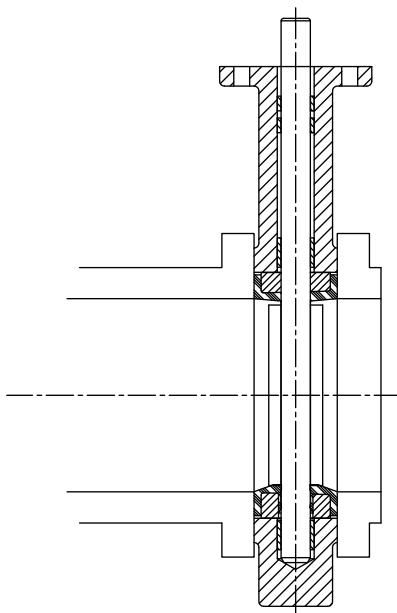

With downstream flange

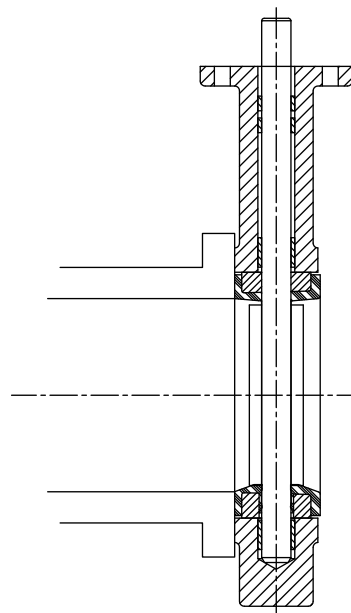

Without downstream flange

Figure Number System - Series 250

Series 250 1 1 2 3 4 5 6 7 8 9 — 10

1. Size	Code	5. Disc	Code	9. Actuator	Code
2"	02	316 SS	4	Handle	2
2½"	25	Aluminum Bronze	6	Infinite/Lockable (2"-6")	3
3"	03	Monel® 400	7	Infinite (8")	4
to				Gear Operator	5
24"	24			Double Acting	6
				Fail Close - SR	7
				Fail Open - SR	8
				Electric	9
				Gear Operator/Balancing	G
				Buried Gear/2" Nut	C
				Direct 2" Nut	D
				Chain Wheel	U
				None	X
2. Series/Style	Code	6. Shaft	Code	10. Special Features	Code
Wafer	2	416 SS	1	Custom Product	D
Lug	4	316 SS	4	CE Marked - Non-Impact Tested	P
Lug DES	6	Monel® (B865-K500 CL-A)	7	CE Marked - Impact Tested	C
		17-4 PH	9		
3. Body	Code	7. Bushings	Code		
Carbon Steel (non-impact)	3	PTFE	3		
316 Stainless Steel	4				
Carbon Steel (impact tested)	E				
4. Pressure	Code	8. Seat/Liner	Code		
200 PSI (2"-12") DES	0	Buna-N	1		
285 PSI	5	Neoprene (black)	3		
150 PSI (14"-24") DES	6	EPDM	5		
125 PSI (2"-12") PTFE	8	Viton® (275°F)	6		
		PTFE/Buna-N	L		
		Viton® (400°F)	P		
		EPDM (FDA)	V		
		White Buna-N (FDA)	W		
		White Buna-N	B		



Figure Number System - Series 700

Series 700



1. Size	Code	4. Pressure	Code	7. Actuator	Code
1"	01	150 PSIG	6	None	X
1½"	15	100 PSIG	4	10 Pos. Handle (DI)	H
2"	02	50 PSIG (undercut)	9	10 Pos. Handle (SS)	S
2½"	25	PTFE coated-disc/stem and seat combination de-rated to 100 psig.		Gear Operator	O
3"	03			Double Acting	6
4"	04	5. Disc/Shaft		Fall Close (SR)	7
5"	05	255 Duplex SS	E	Fall Open (SR)	8
6"	06	255 Duplex SS/PTFE	T	Electric	9
8"	08	255 Duplex SS/EPDM	P		
10"	10	255 Duplex SS/Buna	B		
12"	12				
2. Series/Style	Code	6. Seat	Code		
Split Body Lug	X	Buna-N*	2		
Split Body Wafer	Y	Buna-N White*	W		
		EPDM	5		
		Viton® 400°F	P		
		PTFE/EPDM	M		
		PTFE/Buna-N	L		
		PTFE/Viton®	N		
3. Body	Code				
Ductile Iron - A395	G				
255 Duplex SS	E				
Aluminum	A				

*FDA Approved and Abrasion Resistant.

Figure Number System - Series 800

Series 800

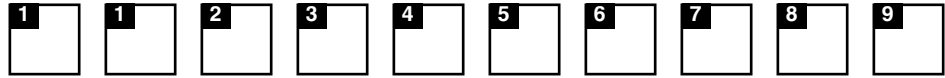

1. Size	Code	4. Pressure	Code	7. Springs	Code
2"	02	150 PSI	6	316 SS	D
2½"	25			Monel® 400	M
3"	03				
to					
20"	20				
2. Series/Style	Code	5. Plate	Code	8. Seat/Liner	Code
Wafer	R	316 SS (2"-14")	4	Buna-N	1
Euro	W	Ductile Iron (6"-20")	5	Neoprene	3
		Aluminum Bronze (2.5"-20")	6	EPDM	5
		Monel® (2"-8")	7	Viton®	0
3. Body	Code	6. Shaft	Code	9. Special Features	Code
Ductile Iron*	1	316 SS	4	CE Marked - Non-Impact Tested	P
Epoxy Coated DI (A536)	S	Monel®	7		

*Cast iron alignment body with a Ductile Iron fully lined valve body.



CRANE Energy Flow Solutions®

CRANE Energy Global Headquarters
19241 David Memorial Drive, Suite 150
Shenandoah, Texas 77385 U.S.A.
Tel.: (1) 936-271-6500
Fax.: (1) 936-271-6510

Center Line Customer Service
9860 Johnson Road
Montgomery, Texas 77316
Tel.: (1) 936-588-8380
Fax.: (1) 936-588-8381

www.craneenergy.com



Energy Flow Solutions

Sydney, Australia Operations
146-154 Dunheved Circuit
St. Mary's, N.S.W. 2760
Sydney, Australia
Tel: +61-29-623-0234
Fax: +61-29-673-3870

Ningjin, China Operations
No. 8 Youyi Street Ningjin County
Hebei Province, China 055550
Tel: +86-319-580-6651
Fax: +86-319-580-8661



brands you trust.



EG-CL-CT-EN-199-05-1102 (CV-110)

Crane Co., and its subsidiaries cannot accept responsibility for possible errors in catalogues, brochures, other printed materials, and website information. Crane Co. reserves the right to alter its products without notice, including products already on order provided that such alteration can be made without changes being necessary in specifications already agreed. All their trademarks in this material are property of the Crane Co. or its subsidiaries. The Crane and Crane brands logotype (Aloyco®, Center Line®, Compac-Noz®, Crane®, Duo-Chek®, Flowseal®, Jenkins®, Krombach®, Noz-Chek®, Pacific Valves®, Stockham®, Triangle®, Uni-Chek®) are registered trademarks of Crane Co. All rights reserved.